

LOW LEVEL ORDER PICKER

PPF SN

Always correct ergonomic level when placing goods, with adjustable height of the forks. Fast acceleration, high top speed and gentle braking means efficient picking. 1200 kg.

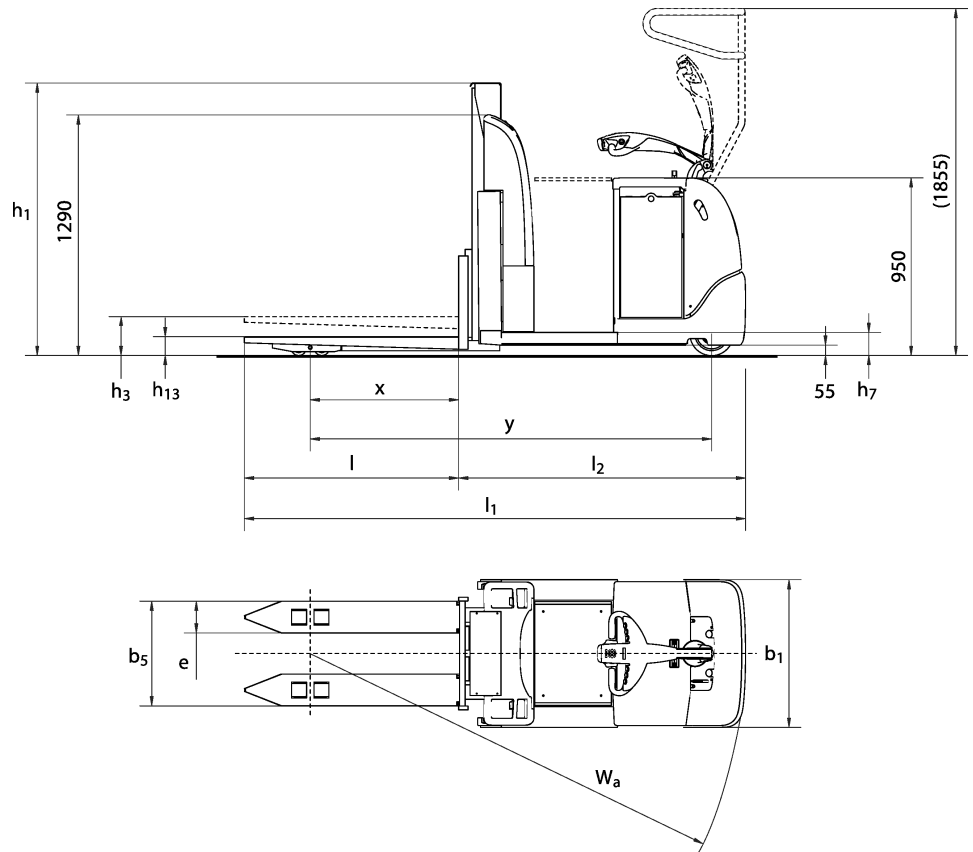

Mast type	Lift height H	Height of mast lowered h1	Max mast height h4
Standard/Duplex			
Triplex			

Distinguishing mark	Specification			PPF SN	
		0			
	1.2	Manufacturer's type designation			
	1.3	Drive: electric (battery or mains), diesel, petrol, fuel gas		Electric	
	1.4	Operator type: hand, pedestrian, standing, seated, order-picker		Hand	
	1.5	Load capacity/rated load	Q t	1,2	
	1.6	Load centre distance	c mm	600	
	1.8	Load distance, centre of load axle to fork		650-1050	
	1.9	Wheelbase	y mm	1358 + x	
Weight	2.1	Service weight incl battery		1300*	
	2.2	Axle load, with load, front/rear		kg	
	2.3	Axle load, without load, front / rear		kg	
	2.4	Axle load, fork outreached with load, front / rear		kg	
	2.5	Axle load, fork retracted with load, front / rear		kg	
Tyres, chassis	3.1	Tyres		Vulcollan	
	3.2	Tyre size, drive side		mm	
	3.3	Tyre size, load side		mm	
	3.4	Dimensions additional wheels (castor wheels)		mm	
	3.5	Wheels, number front/rear (drive side/load side, x = driven wheels)		1x 1/4	
	3.6	Track, drive side	b10 mm	500	
	3.7	Track, load side	b11 mm	V-170	
Dimensions	4.1	Tilt of mast/fork carriage, forward/backward		Grad	
	4.2	Height, mast lowered		h1 mm	
	4.3	Free lift		h2 mm	
	4.4	Lift height H = h1+h3		H mm	
	4.5	Height, mast extended		h4 mm	
	4.6	Straddle lift		h5 mm	
	4.7	Height of overhead guard (cabin)		h6 mm	
	4.8	Seat height/stand height		h7 mm	
	4.10	Height of wheel arms		h8 mm	
	4.11	Additional lift		h9 mm	
	4.14	Stand height, elevated		h12 mm	
	4.15	Height lowered		h13 mm	
	4.19	Overall length		l1 mm	
	4.20	Length to face of forks		l2 mm	
	4.21	Overall width		b1 mm	
	4.21.1	Width over stabilizers		mm	
	4.22	Fork dimensions		s/e/l mm	
	4.23	Fork carriage to ISO 2328, clas / form A, B			
	4.24	Width of fork carriage		b3 mm	
	4.25	Width over forks, min/max		b5 mm	
	4.26	Distance between wheel arms		b4 mm	
	4.27	Width across guide rolls		b6 mm	
	4.28	Reach distance		l4 mm	
	4.29	Reach lateral		b7 mm	
	4.30	Reach lateral from vehicle centerline		b8 mm	
	4.31	Ground clearance, mast		m1 mm	
	4.32	Ground clearance, centre of wheelbase		m2 mm	
	4.33	Aisle width with pallet 1000 x 1200, crosswise		Ast mm	
	4.34	Aisle width for pallet 800 x 1200, lengthwise		Ast mm	
		Transfer aisle		0 mm	
	4.35	Turning radius		Wa mm	
	4.37	Length incl reach legs		l7 mm	
	4.38	Distance to swivelling-fork pivot		0 mm	
	Performance data	5.1	Travel speed, with/without load		km/h
		5.1.1	Travel speed with/without load, backwards		km/h
		5.2	Lift speed, with/without load		m/s
		5.3	Lowering speed, with/without load		m/s
		5.4	Reach speed, with / without load		m/s
5.7		Gradient, with/without load		%	
5.8		Max gradeability, with / without load, 5 min rating		%	
5.9		Acceleration time 0-10 m, with/without load		s	
5.10		Service brake: electric, hydraulic		Electric	
5.10.1		Parking brake: electric, hydraulic		Electric	
Electric engine	6.1	Drive motor, rating S2 60 min		kW	
	6.2	Lift motor		kW	
	6.3	Battery according to DIN 43531/35/36		A,B,C	
	6.4	Battery voltage / Battery capacity		V/Ah	
	6.5	Battery weight		kg	
	6.6	Power consumption according to VDI cycle		kWh/h	
Additional data	8.1	Speed regulation		AC Transistor	
	10.1	Operating pressure attachments		bar	
	10.2	Oil flow for attachments		l/min	
	10.7	Noise level at operator's ear, according to EN 12 053		db(A)	

* Varies according to battery size

All rights reserved to change above specification